



Small Filter Housings

VF-31E, VF-61, VF-609

Clean Dry Fuels and Oils with High Performance

FEATURES

- Wide variety of applications
- Free and emulsified water to less than 5 ppm
- 1/2 micron particulate removal
- Provides protection against “slugs” of water
- Pressure increase signals cartridge change

These filter housings are versatile housings designed for use with several different high performance **Aquacon**[®] and other filter cartridges. Refer to the cartridge selection table on page 3 for application and other details.

Aquacon[®] cartridges filter out water by chemically locking it into layers of super-absorbent media. Water capacity is as much as 1½ quarts, depending on the specific vessel and cartridge. These cartridges also effectively filter out dirt, rust and other particulates. (See caution, back cover.)

As an **Aquacon**[®] cartridge reaches its water-holding limit, the media expands very rapidly and restricts the flow. The pressure drop will rapidly increase, signaling the need to change cartridges.

The VF-61, with **Aquacon**[®] ACO series cartridges installed, has become the standard for low flow rate full flow aviation fuel monitor applications.

APPLICATIONS

- Jet Fuel
- Avgas
- Motor Gasoline
- Diesel Fuel
- Biodiesel
- Selected Solvents
- Oils: Insulating Hydraulic Lubricating
- Compressed Air
- Other Gasses



VF-31E



VF-61*



VF-609



VF-61 connected to a diesel fuel dispenser

***Also available: VF-61UL Filter Housing, for diesel fuels. Recognized under the Component Recognition Program of Underwriters Laboratories Inc.**

DIMENSIONAL DRAWINGS

Please note: Drawings are not to scale. Dimensions are shown for estimating purposes only.

VF-31E

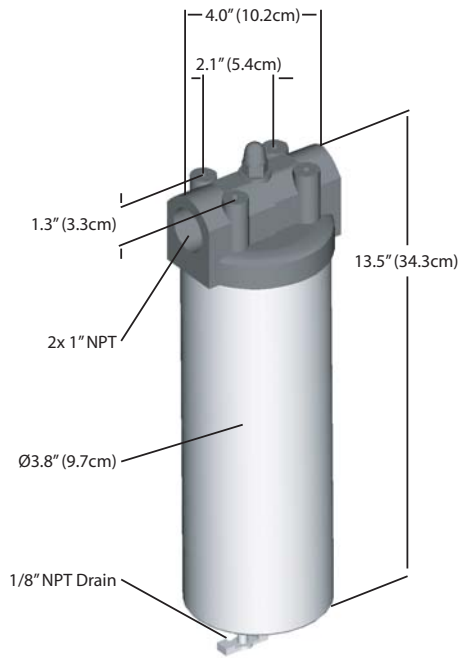

VF-609

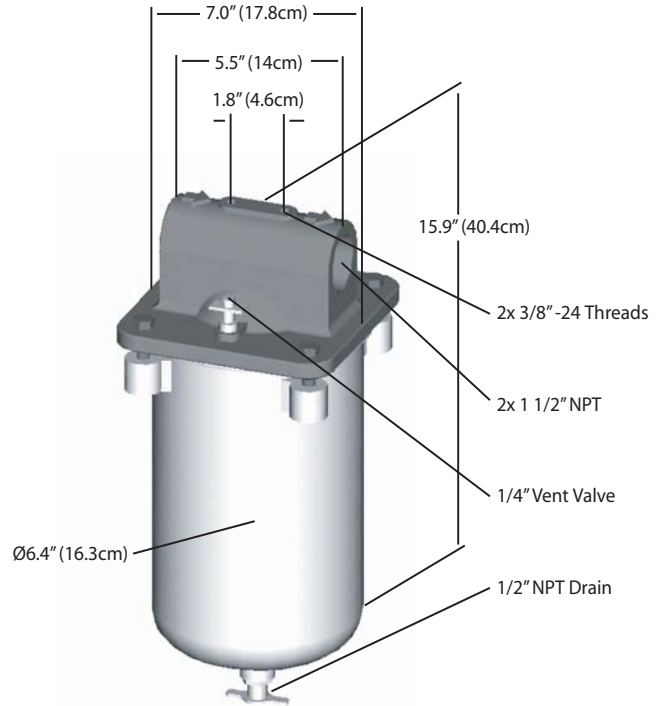

VF-61

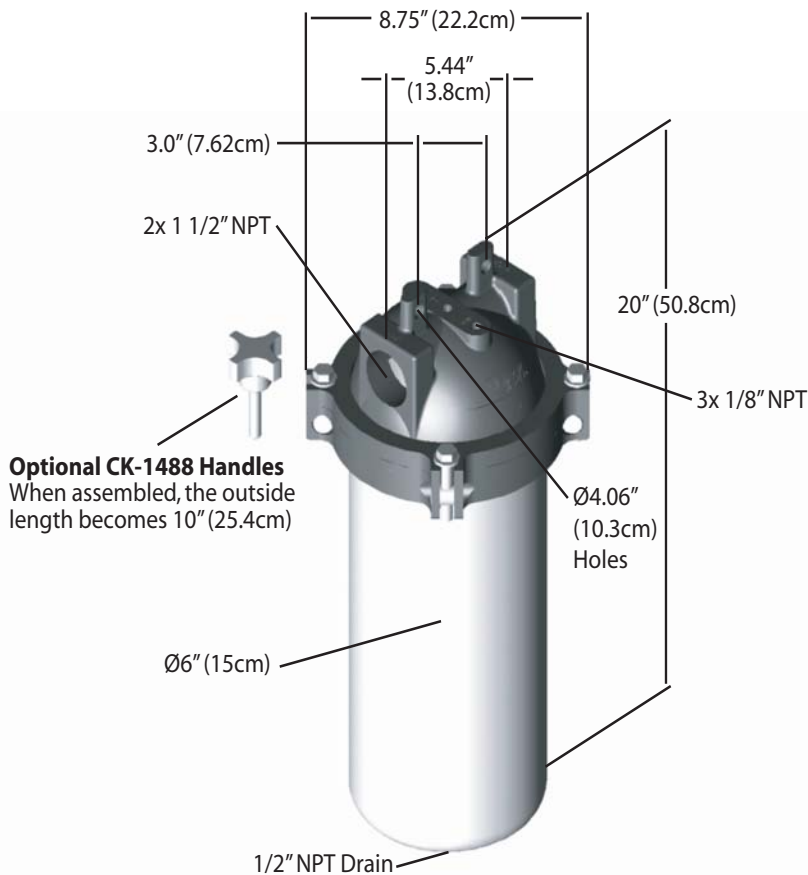

OPTIONAL ACCESSORIES - DIFFERENTIAL PRESSURE GAUGES

See page 4 for ordering information



**P/N 10678
for VF-61**



**P/N 07-224
for VF-609**

*Optional mounting block
for gauge,
P/N 07-224AMB,
not shown*

FILTER CARTRIDGE SELECTION TABLE

Housing P/N	Product being filtered	Application	Cartridge P/N	Data Sheet	Type	Micron	Flow Rate (GPM)
VF-31E	Jet Fuel & Avgas ⁽¹⁾	Dirt & Free water	ACO-21001L	1681	Aquacon [®] (Absorbent)	0.5	1-15
	Mo-gas		AC-21005	1582		5	
	Gasohol	Dirt	FOG-21005	N/A	Paper filter	5	1-15
	Diesel ⁽¹⁾	Dirt & Free water	AD-21025	1655	Aquacon [®] (Absorbent)	25	1-15
	Oils		AC-21005	1582		5	Varies with oil viscosity ⁽²⁾
			AD-21025	1655		25	
	Air/Gas		ACA-210	1689		1	100 SCFM @ 100 psig
	Dirt	FOS-210PLP5	N/A	Synthetic Filter	0.5		
VF-61	Jet Fuel & Avgas ⁽¹⁾	Dirt & Free water	ACO-512P3L	1681	Aquacon [®] (Absorbent)	0.3	5-50
			ACO-51201L			0.5	5-50
			OS-51288	1858	Coalescer/ Separator	0.5	Jet: 5-35 Avgas: 5-45
	Mo-gas		AC-51205	1582	Aquacon [®] (Absorbent)	5	5-50
	Diesel ⁽¹⁾		AD-51225	1655		25	15-50
			OS-51286	1858	Coalescer/ Separator	5	5-18
	Oils		AC-51205	1582	Aquacon [®] (Absorbent)	5	Varies with oil viscosity ⁽²⁾
			AD-51225	1655		25	
	Solvents		ASL-51201	1692		1	5-50
	ALL		Dirt	FO-512PL1/2	1549	Paper Filter	0.5
		FO-512PL05		5			
		FO-512PL25		25			
		FOS-512PL25		1734	Synthetic Filter	25	
VF-609	Jet Fuel & Avgas ⁽¹⁾	Dirt & Free water	ACO-609P3L	1681	Aquacon [®] (Absorbent)	0.3	15-36
			ACO-60901L			0.5	
			ACO-60905L			5	
	Diesel ⁽¹⁾		OS-60988	1858	Coalescer/ Separator	0.5	Jet: 5-35 Avgas: 5-45
			AD-60925	1655	Aquacon [®] (Absorbent)	25	15-30
			OS-60986	1858	Coalescer/ Separator	5	5-18

NOTES:

(1) For aviation and diesel fuel applications, always install a differential pressure gauge or other means of determining differential pressure.

(2) See Data Sheet #1709 for absorbent cartridge (AC, AD) flow rates.

(3) See Data Sheet # 1532 for paper filter (FO) flow rates, see Data Sheet # 1747 for synthetic filter (FOS) flow rates. For Biodiesel applications, please contact Velcon.

Please consult installation instructions and operating procedures that accompany products for more detailed information.

ORDERING INFORMATION

(Please note: Cartridges are NOT supplied. They must be ordered separately)

HOUSING P/N:	VF-31E	VF-61	VF-609
SUPPLIED WITH:	<ul style="list-style-type: none"> 1 ea P/N G-0995 Buna-N O-ring Mounting holes in head - 4 ea 1/4-20 NC 1 ea plug (for fuel & oil applications) 1 ea 1/8" petcock drain (for air, gas, & aviation fuel applications) 	<ul style="list-style-type: none"> 1 ea P/N G-0986 Buna-N O-ring 1/8" brass petcock vent valve, installed 1/2" drain plug, installed 1 ea 1/2" petcock drain, shipped loose 	<ul style="list-style-type: none"> 1 ea P/N G-0565 Buna-N O-ring 1/4" brass petcock vent valve 1/2" drain valve
RECOMMENDED SPARES	<ul style="list-style-type: none"> 1 ea P/N G-0995 Buna-N O-ring 4 ea replacement filter cartridges 	<ul style="list-style-type: none"> 1 ea P/N G-0986 Buna-N O-ring 6 ea replacement filter cartridges 	<ul style="list-style-type: none"> 1 ea P/N G-0565 Buna-N O-ring 6 ea replacement filter cartridges
If using with gasoline/solvent applications:		<ul style="list-style-type: none"> 2 ea P/N G-0986A Viton O-rings 	<ul style="list-style-type: none"> 2 ea P/N G-0565A Viton O-rings
OPTIONS	N/A	<ul style="list-style-type: none"> P/N 554Y020 - (carbon steel 1/2" NPT ball valve, with mounting nipple) P/N 10678 - (differential pressure gauge assembly) P/N CK-1488 (quick release hand bolts) 	<ul style="list-style-type: none"> P/N 554Y020 - (carbon steel 1/2" NPT ball valve, with mounting nipple) P/N 07-224 - (differential pressure gauge assembly) PN 07-224AMB (mounting block)
SPECIFICATIONS			
Weight	3 lbs, 15 oz	8 lbs	8 lbs
Shipping Weight	4 lbs, 15 oz	10 lbs	10 lbs
Inlet/Outlet Connection	1" NPT	1 1/2" NPT	1 1/2" NPT
Cover	Bolted	Bolted, 4 bolts	Bolted, 4 bolts
Maximum Operating Pressure: 150 psi			
Material: Cast aluminum head, carbon steel shell with epoxy powder coated exterior & interior			

OVER PRESSURE PROTECTION

When exposed to a high concentration of water, the differential pressure across an absorbent cartridge (AC, ACO, AD, or ASL Series cartridges) will immediately increase. Pressure bypasses or other means to limit the inlet pressure to 75 psi (5 bar) should be installed to prevent cartridge from collapsing.

CAUTION

To protect the fuel system, including the VF-609 & other components, be sure to install pressure relief valve(s).

CAUTION

Do not use **Aquacon**[®] absorbent cartridges (AC, ACO, AD or ASL Series) with pre-mixed jet fuel containing anti-icing additives, or with gasoline/alcohol blends.



Velcon products are sold and serviced by a world-wide representative network. To order, contact Headquarters or your LOCAL REPRESENTATIVE:

COMPANY HEADQUARTERS:
 Velcon Filters, Inc.
 1210 Garden of the Gods Road
 Colorado Springs, CO 80907-3410
 Phone: 1.800.531.0180 / 1.719.531.5855
 Fax: 719.531.5690
 e-mail: vfsales@velcon.com
 www.velcon.com

MANUFACTURING PLANTS LOCATED AT:
 Colorado Springs, Colorado
 Sylacauga, Alabama
 Henryetta, Oklahoma

OVERSEAS AFFILIATES:
 Germany, Spain, Canada & Singapore

**Liquid Filtration
 and Separation
 Specialists**